

THE PHOTOMETRIC CHARACTERISTICS OF LUMINAIRES

4.1 Generalities

The main part of a luminaire is the lamp, which is defined as the ensemble formed by the light source, the distribution system, the spatial repartition of the light flux (reflector) and the mechanical resistance system (reinforcing steel) in which are placed the lamp's accessories (ballast, starter, sockets). The main function of a luminaire is the rational redistribution of the flux emitted by the light source in order to obtain, in an economical way, the prescribed light level, on the usable area. The second function of the luminaire is the protection of the eye from the high luminance of the lighting source, and it is as important as the main function. In order to accomplish this task the reflector covers the lamp with opaque parts or with broadcast transmitters, lowering the harmful influence over the eyes.

From the point of view of the utilization area, we have close action luminaires (of general use), far action luminaires (projector type), signaling, projecting or irradiating luminaires. From the phototechnic point of view, luminaires have the following characteristics: polar curve, isolux curves, efficiency, local light flux distribution, protection angle, amplification factor, maintaining illuminance coefficient and protection degree.

4.2 The polar curve of the luminaires

The spatial distribution of the luminous intensity of a luminaire is given by the photometric surface represented by the luminous intensity vectors' hodograph. This surface delineates the photometric body which admits or not a symmetry plane. The intersection of the photometric surface with a meridian plane which contains the luminaire optical axis is called polar curve. This curve can be described through a chart or is drawn in polar coordinates for the conventional lamp of 1000lm.

The polar axis coincides with the optical axis of the luminaire and the reference system 0 (zero) pole is considered in the center of the lighting source or of the luminaire.

The lighting sources of which the photometric body is a body of revolution are called symmetric sources and the polar curves (fig.4.1-a) have the same shape no matter what the secant meridian plane is. The light sources of which photometric body doesn't admit a symmetry axis are called asymmetry sources and the polar curves have different shapes in different meridian planes, whence the necessity of the polar curves family (fig.4.1-b).

In polar coordinates the polar curves can be analytically expressed under the form:

$$I_{\alpha} = f(\alpha) \quad \text{or} \quad I_{\alpha\beta} = f(\alpha, \beta)$$

where:

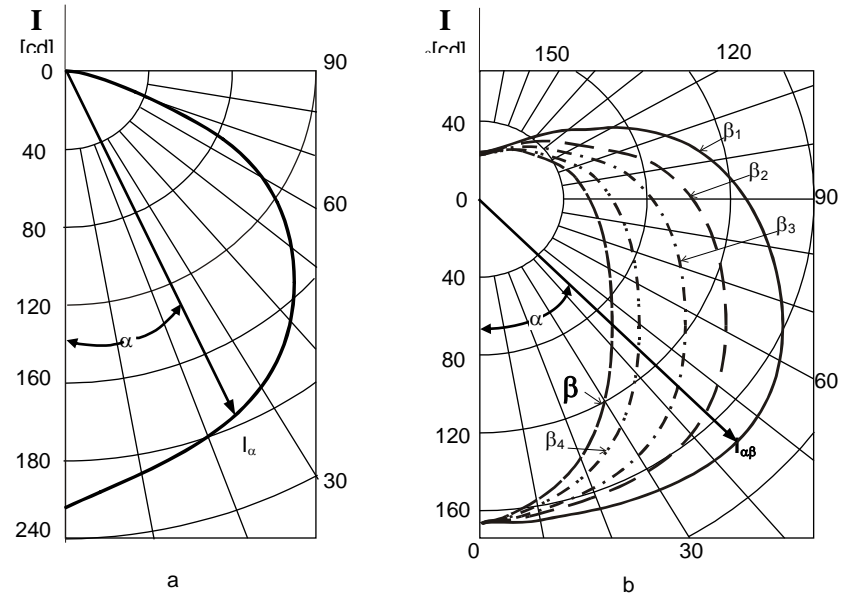

Fig.4.1 Polar curves for the symmetric (a) and asymmetric (b) luminaires

α - elevation angle, defined as the angle between the direction of the luminous intensity and the light source axis (is measured in the secant meridian plane);

β - azimuth angle, is the dihedral angle formed between the reference meridian plane and the current meridian plane.

4.3 The isolux curves of the luminaires

The isolux curves are useful for the design of the interior or exterior luminaires through the point by point method. Depending on the initial conditions there are:

- relative isolux curves representing the geometrical place of the points which have the same illuminance, located in the normal q plane on the optical axis of the source, at the distance of one meter from it (a conventional plane);

- spatial isolux curves representing the geometrical place of the space points which have the same illuminance and belong to the normal planes on the optical axis of the source.

To draw the isolux curves it is necessary to know the polar curve of the luminaire, as well as the recurrence relation between the illuminance and the luminous intensity related to a calculation point included in the normal plane (H or q) on the luminaire's optical axis (fig.4.2-a).

Thus, at the drawing of the relative isolux curves, the relative illuminance ϵ_r of the point p from the conventional plane q is:

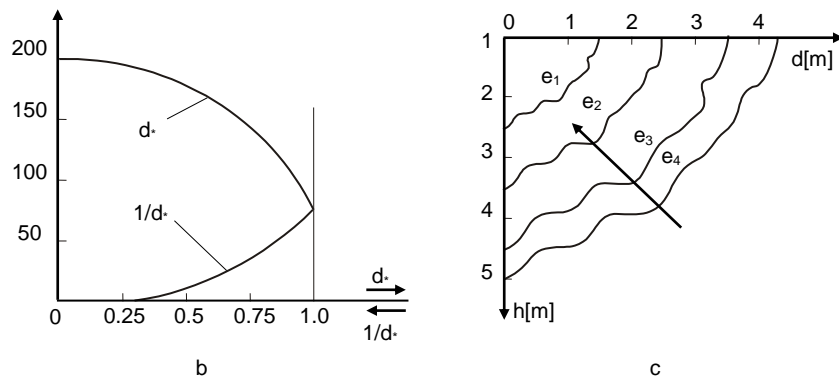
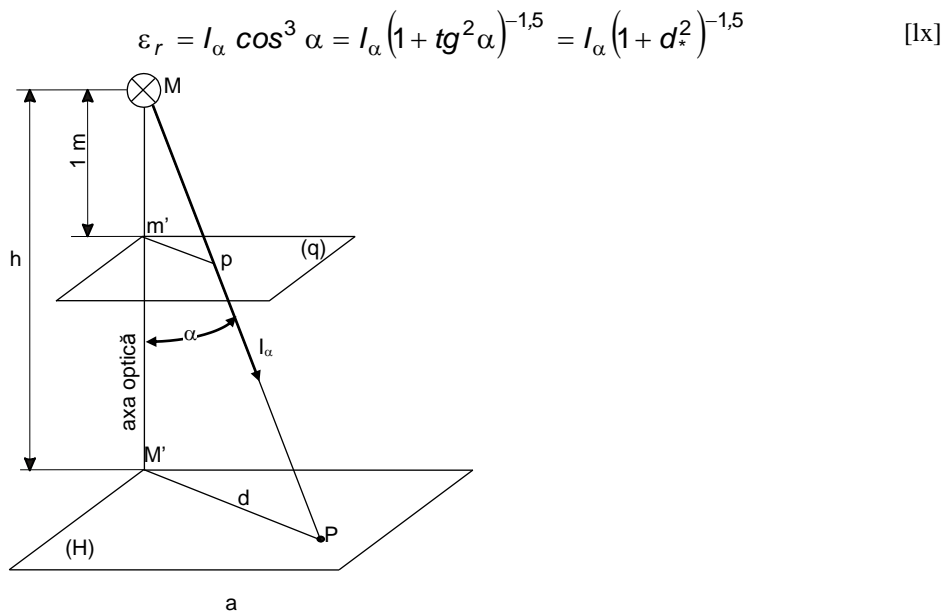

Fig.4.2 Explanatory (a) for the drawing of the relative (b) and spatial (c) and isolux curves if the angle α is imposed, we extract from the polar curves the values I_α and it results, in the end, the dependence $I_\alpha=f(d^*)$. In the case of the symmetric lamps the function chart $\varepsilon_r=f(d^*)$ has two branches (fig.4.2-b) a decreasing one for $\alpha \in [0, \pi/4]$ sau $d^* \in [0, 1]$ and a increasing one for $\alpha \in [\pi/4, \pi/2]$ sau $1/d^* \in [0, 1]$. It is to mention that this kind of curves can be drawn also for the asymmetric luminaires.

On the same direction α , the correspondent of p is P from plane H of which the illuminance is:

$$e = I_\alpha \cdot \cos^3 \alpha / h^2 = \varepsilon_r / h^2 \quad [\text{lx}]$$

where:

h - distance from the luminaire to the computation plane, [m];

d - distance between calculation point-projection of the center of the lamp on the useful plane, [m];

$d^*=d/h=\operatorname{tg} \alpha$ -relative (reported) distance (coordinate) of the computation point.

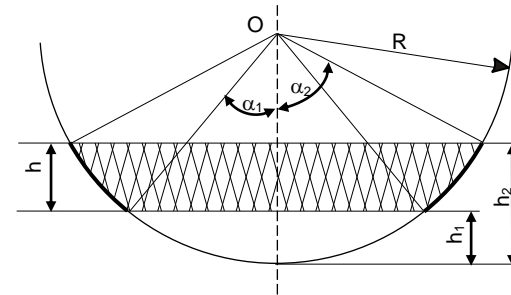

Fig 4.3 Explanatory for defining the angular coefficient

The methodology to draw the spatial isolux curves consists in the following steps:

-it is imposed the value e of the illuminance for which is drawn the isolux curve;

-there are given values for the α angle and there are extracted the values I_α from the polar curve;

-there are determined the cartesian coordinates of the isolux curve points;

$$h = \sqrt{\frac{I_\alpha \cos^3 \alpha}{e}} \quad \text{and} \quad d = h \cdot \operatorname{tg} \alpha \quad [\text{m}]$$

-the function $h=f(d)e=ct$ is graphically represented (fig.4.2-c);

It must be noted that this spatial isolux curves can be drawn only for symmetrical luminaires.

4.4 The luminaire efficacy

The luminaire efficacy η_c is defined as the ratio between the emitted luminous flux ϕ_c of the luminaire and the flux of the light source ϕ_{iz} :

$$\eta = \phi_c / \phi_{iz}$$

denoting that the flux estimation ϕ_c is determined by means of numerical methods (graphical-analytical) or graphical.

a. The graphical-analytical methods are based on the hypothesis that the luminous flux $\Delta\phi$ emitted in the solid angle $\Delta\omega$ is equal with the product between the size of that angle and the average luminous intensity I_m of that angle:

$$\Delta\phi = I_m \cdot \Delta\omega \quad [lm]$$

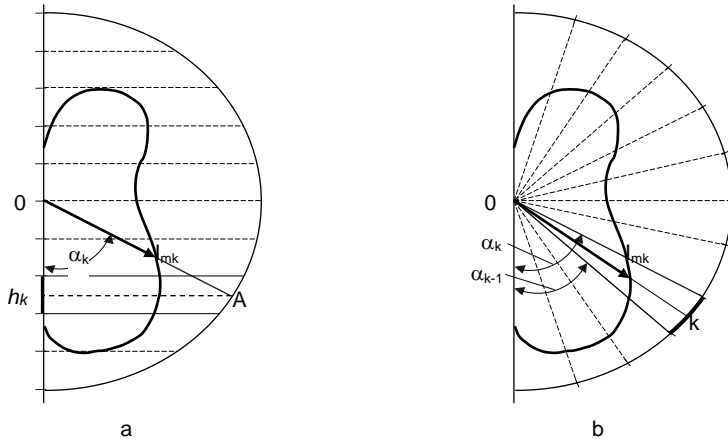

Fig.4.4 Explanatory for the equal solid angles (a) and plane angles (b) methods

If $\Delta\omega$ is the solid angle under which it is seen, from the center of the sphere, a random spherical area (fig.4.3), then its value will be:

$$\Delta\omega = \frac{2\pi(h_2 - h_1)R}{R^2} = \frac{2\pi h}{R} = 2\pi(\cos\alpha_1 - \cos\alpha_2) \quad [sr]$$

which is named *angular coefficient* for the α_2 - α_1 area.

Observing this relationship it is denoted:

- at the spherical areas having equal height h , equal angular coefficients match.
- the angular coefficients can be determined if there are known the plane angles α formed between the generators of the cones which determines the solid angle and their axis.

Based on this observation there were imposed two methods of numerical calculus of the luminous flux emitted by a symmetrical luminaire which has the polar curve known:

✓ **the equal solid angles method** according to which through the separation of the diameter of the sphere D in n equal parts ($h = h_2 - h_1 = h_k = D/n = 2R/n$) there are obtained equal angular coefficients $\omega\Delta = 4\pi/n$ [sr].

The luminous flux $\Phi\Delta k$ of the k area, respectively Φ_c will be:

$$\Delta\Phi_k = \frac{4\pi}{n} \cdot I_{mk} \quad \Phi_c = \sum_{j=1}^n \frac{4 \cdot \pi}{n} \cdot I_{mj} = 4 \cdot \pi \cdot I_{ms} \quad [lm]$$

having I_{ms} -spherical average luminous intensity, numerically equal with the arithmetic average of the corresponding luminous intensities of the n spherical areas.

Applying the method consists in the circumscription of a semicircle (fig.4.4-a) to the polar curve and dividing its diameter in $n = 10$ or 20 equal parts.

The average calculus luminous intensity I_{mk} , for k areas, its read by the OA given by the center of the source O and the intersection point A between the semicircle and the mediator of the h_k segment. For fast calculations, the angle α_k between the average luminous intensity I_{mk} and the source axis is given in the Annex 4.1.

✓ **the equal planes angles method** according to which through the separation of the big semicircle of the sphere in n^* equal parts it is obtained, for the k area delimited by the α_{k-1} , α_k angles, the following angular coefficient:

$$\Delta\omega_k = 2\pi(\cos\alpha_{k-1} - \cos\alpha_k) = 2\pi \left[\cos(k-1) \frac{\pi}{n^*} - \cos k \frac{\pi}{n^*} \right] \quad [sr]$$

and the following area flux:

$$\Delta\Phi_k = I_{mk} \Delta\omega_k$$

which leads to a total flux of the luminaire equal with:

$$\Phi_c = \sum_{j=1}^{n^*} \Delta\Phi_j = 2\pi \sum_{j=1}^{n^*} \left[\cos(j-1) \frac{\pi}{n^*} - \cos j \frac{\pi}{n^*} \right] \cdot I_{mj} \quad [lm]$$

The practical application of the method consists in the circumscription of a semicircle to the polar curve (fig.4.4-b) and dividing it in $n^* = 18$ or 36 equal parts. The average luminous intensity I_{mk} , of the k area, its read by the bisector of the α_k - α_{k-1} angle. For faster calculations, the angular coefficients $\omega\Delta k$ for $n^* = 18$ are given in the Annex 4.2.

b. The graphical methods, which can be especially applied for the symmetrical luminaires, consists in the graphical calculation of the analytical expression of the luminous flux

$$\Phi = 2\pi \int_0^\pi I_\alpha \cdot \sin\alpha \cdot d\alpha \quad [lm]$$

by transposing from polar coordinates in cartesian coordinates of the polar curve.

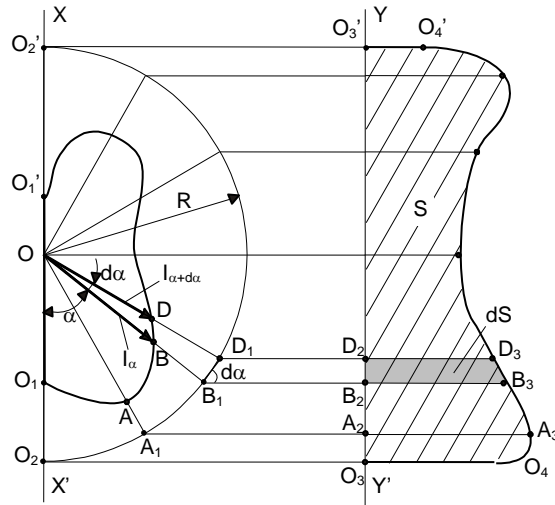

Fig.4.5 Explanatory for the graphical method

mm/ cd] is a luminous intensity scale;

- repeat the described procedure for a large enough number of points and it results the boundary O3, O4, A3 ...O4', O3' named **Rousseau curve**.

The area S delimited by the Rousseau curve and the axis YY' is proportional with the flux Φ_c of the luminaire, fact that is easily showed if we consider an infinitesimal increase $d\alpha$ of the elevation angle, to which it corresponds the area element.

$$dS = B_2B_3 \cdot B_2D_2 = a \cdot I_\alpha \cdot R \cdot B_1D_1 \cdot \sin\alpha \cong a \cdot I_\alpha R \cdot \sin\alpha \cdot d\alpha \quad [\text{mm}^2]$$

Keeping in mind that: $d\Phi = 2\pi \cdot I_\alpha \sin\alpha \cdot d\alpha$ and $d\Phi = 2\pi \cdot dS / (aR)$ then:

$$\Phi = \frac{2\pi}{aR} S \quad [\text{lm}]$$

4.5 Zonal distribution of the luminous flux

Zonal distribution of the luminous flux (fig.4.6) represents the rate of the luminous flux of the light source which is emitted in solid angles of which axis concurs with the one of the luminaire. If, for example, we calculate the flux of the lamp using the equal plane angles method then for the area $0 \dots 40^\circ$ we'll notice that:

One of the most used approach is the Rousseau graphical method, presented in (fig.4.5):

- it circumscribes to the polar curves a semicircle having the radius R , of which center O concurs with the luminaire center;

- at an arbitrary distance from the axis of the source XX' is drawn the parallel YY' ;

- the radius vector OB is extended, corresponding to the luminous intensity I_α to the intersection with the semicircle in B_1 ;

- the point B_1 , is projected in the direction YY' in B_2 ;

- the segment B_1B_2 is extended with the $B_2B_3 = aI_\alpha$, where a

$$\Phi_Z \% = \frac{\Phi_0 - 40}{\Phi_{iz}} 100 \quad \text{cu} \quad \Phi_0 - 40 = 2\pi \sum_{j=1}^4 \left[\cos(j-1) \frac{\pi}{n} - \cos \frac{\pi}{n} \right] \cdot I_{mj} \quad [\text{lm}]$$

4.6 Protection/Shielding angle

The shielding angle δ of a luminaire delineates the area from the space outside of which the eye doesn't perceive the high luminance (brightness) elements of the light source. For a given meridian plane (fig.4.7), the shielding angle is measured between the opening plan of the luminaire and the line connecting the opening edge with the opposed extremity of the light source, which leads to:

$$\delta = \arctg \frac{h}{R+r}$$

noting that the dimensions h , R and r have the same meaning as in the figure bellow.

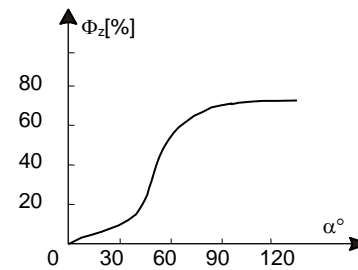

Fig.4.6 Zonal distribution $\Phi_z=f(\alpha)$

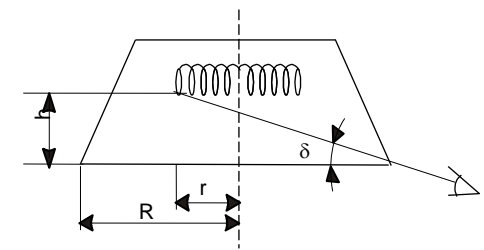

Fig.4.7 Explanatory to the shielding angle

4.7 The amplification factor

The amplification factor m it is defined as the ratio between the maximum luminous intensity I_{mx} and the spherical average luminous intensity I_{ms} of the lamp:

$$m = \frac{I_{mx}}{I_{ms}} = \frac{4\pi I_{mx}}{\Phi_c}$$

4.8 The maintenance factor

The maintenance factor Δ of a luminaire is given by the ratio between the emitted luminous flux in the period of exploitation Φ_{ce} and the initial flux Φ_{ci} at the start of the operating period:

$$\Delta = \Phi_{ce} / \Phi_{ci} < 1,$$

its value being lower than 1 because of the wear of the light source, the impairment of the photometric properties of the reflector's materials, dust deposits etc.

Keeping this parameter in reasonable limits can be achieved through periodic cleaning of the luminaire and replacing of the light sources at the expiration date. In design calculations it's operating with the reverse of this parameter, named *depreciation factor* or *depreciation coefficient*.

$$k = 1/\Delta > 1$$

4.9 The protection degree

The protection degree of a luminaire is symbolized through the alphanumeric group IPμστ, having the following significance: IP – protected fitting, τ- protection against ingress of foreign bodies, σ - protection against ingress of liquids, μ□- protection against mechanical damages. Depending on the environmental conditions in which the lamp is going to be mounted, exploited and maintained a proper level of protection is chosen.

4.10 Laboratory work layout

The laboratory classes focus on the following theoretical and practical problems:

- it will be graphically represented a tabular polar curve of a luminaire which is equipped with a low-pressure mercury vapor conventional fluorescent lamp.
- it will be drawn the relative isolux curves of the luminaire, and a spatial isolux curve having the value e ;
- it will be determined the luminaire efficiency η_c through estimating Φ_c utilizing the equal solid angles method for $n=20$, the equal plan angles method for $\pi/n^*=\pi/18=10^\circ$
- it will be drawn the zonal distribution of the luminous flux using the results obtained with the equal plan angles method.
- it will be determined the amplification factor m operating with the 3 previously calculated values of the flux Φ_c ;
- there will be written the conclusions of the study.

Annex 4.1 The value of α_k angle between the average luminous intensity Im_k and the axis of the source in the case of dividing the diameter of the semicircle in n equal parts.

$n = 10$

α_k°	26	46	60	75	84
α_k°	96	107	120	134	154

$n = 20$

α_k°	18	32	41	49	57
------------------	----	----	----	----	----

α_k°	63	70	76	81	87
α_k°	93	99	104	110	117
α_k°	123	131	139	148	162

Annex 4.2 Angular coefficients ω_k

$$\omega_k = 2 \cdot \pi \cdot \left[\cos(k-1) \frac{\pi}{n^*} - \cos k \cdot \frac{\pi}{n^*} \right] \quad \text{for } n^* = 18 \quad \text{and} \quad \frac{\pi}{n^*} = 10^\circ$$

Zona	0-10°	10°-20°	20°-30°	30°-40°	40°-50°
ω_k	0.095	0.283	0.463	0.628	0.774
Zona	50°-60°	60°-70°	70°-80°	80°-90°	
ω_k	0.897	0.993	1.058	1.091	
Zona	90°-100°	100°-110°	110°-120°	120°-130°	130°-140°
ω_k	1.091	1.058	0.993	0.897	0.774
Zona	140°-150°	150°-160°	160°-170°	170°-180°	
ω_k	0.628	0.463	0.283	0.091	

